



± 10g Tri-Axis Accelerometer Specifications

PART NUMBER:

KXD94-2802

Rev. -
Dec 08

Product Description

The KXD94-2802 is a silicon micromachined accelerometer with a full-scale output range of $\pm 10g$ ($\pm 98 \text{ m/s}^2$). The sense element is fabricated using Kionix's proprietary plasma micromachining process technology. Acceleration sensing is based on the principle of a differential capacitance arising from acceleration-induced motion of the sense element, which further utilizes common mode cancellation to decrease errors from process variation, temperature, and environmental stress. The sense element is hermetically sealed at the wafer level by bonding a second silicon lid wafer to the device using a glass frit. A separate ASIC device packaged with the sense element provides signal conditioning and self-test. The accelerometer is delivered in a 5 x 5 x 1.2 mm DFN plastic package operating from a 2.5 – 5.25V DC supply.

Figure 1. Functional Diagram

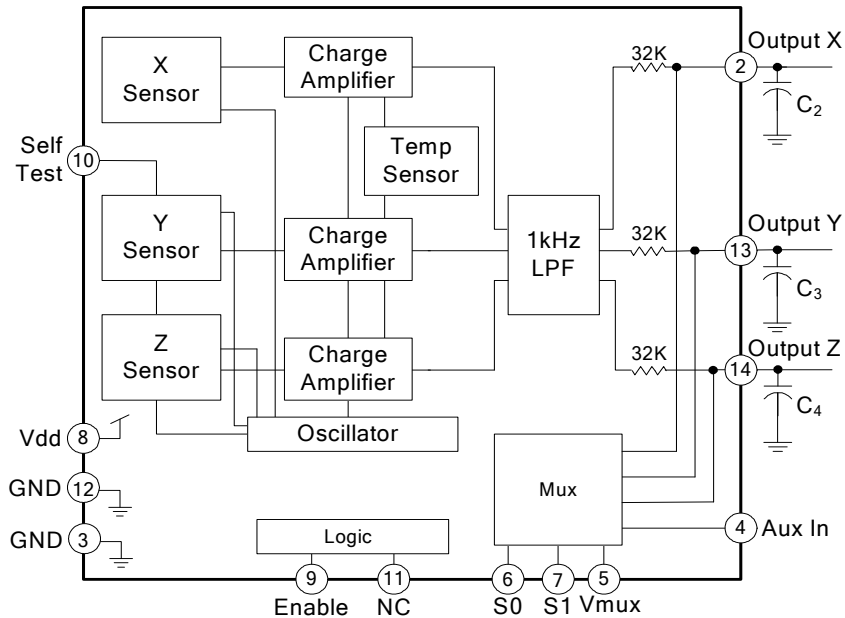

	± 10g Tri-Axis Accelerometer Specifications	PART NUMBER: KXD94-2802 Rev. - Dec 08
---	--	--

Product Specifications

Table 1. Mechanical

(specifications are for operation at $V_{dd} = 5.0\text{ V}$ and $T = 25^{\circ}\text{C}$ unless stated otherwise)

Parameters	Units	Min	Typical	Max
Operating Temperature Range	$^{\circ}\text{C}$	-40	-	85
Zero-g Offset	V	2.45	2.50	2.55
Zero-g Offset Variation from RT over Temp.	$\text{mg}/^{\circ}\text{C}$		± 1.0	
Sensitivity	mV/g	193	200	207
Sensitivity Variation from RT over Temp.	$\%/^{\circ}\text{C}$		± 0.01	
Offset Ratiometric Error ($V_{dd} = 5.0\text{V} \pm 5\%$)	%		± 0.2 (xy) ± 0.1 (z)	
Sensitivity Ratiometric Error ($V_{dd} = 5.0 \pm 5\%$)	%		± 1.6 (xy) ± 0.2 (z)	
Non-Linearity	% of FS		0.1	
Cross Axis Sensitivity	%		2.0	
Self Test Output change on Activation	g		6.5 (xy) 3.6 (z)	
Bandwidth (-3dB) ¹	Hz		800	
Noise Density (on filter pins)	$\mu\text{g} / \sqrt{\text{Hz}}$		100	

Notes:

1. Internal 1 kHz low pass filter. Lower frequencies are user definable with external capacitors.

Table 2. Electrical

(specifications are for operation at $V_{dd} = 5.0\text{ V}$ and $T = 25^{\circ}\text{C}$ unless stated otherwise)

Parameters		Units	Min	Typical	Max
Supply Voltage (V_{dd})	Operating	V	2.5	5.0	5.25
	Standby	μA	-	-	5
Current Consumption	Operating	mA	0.90	1.20	1.50
Input Voltage for Logic Low ¹		V	-	-	$0.2 * V_{dd}$
Input Voltage for Logic High ¹		V	$0.8 * V_{dd}$	-	-
Analog Output Resistance (R_{out})		$\text{k}\Omega$	24	32	40

Notes:

1. The voltage level required for enabling or disabling self-test function or selecting multiplexer output.

	± 10g Tri-Axis Accelerometer Specifications	PART NUMBER: KXD94-2802 Rev. - Dec 08
---	--	--

Table 3. Environmental

Parameters		Units	Min	Target	Max
Supply Voltage (V_{dd})	Absolute Limits	V	-0.3	-	7.0
Maximum Operating Temperature Range		°C	-40	-	125
Storage Temperature Range		°C	-55	-	150
Mech. Shock (powered and unpowered)		g	-	-	5000 for 0.5ms
ESD	HBM	V	-	-	3000

CAUTION:
ELECTROSTATIC
SENSITIVE COMPONENT



Caution: ESD Sensitive and Mechanical Shock Sensitive Component, improper handling can cause permanent damage to the device.

The QFN plastic package conforms to European Union Directive 2002/95/EC on the restriction of the use of certain hazardous substances in electrical and electronic equipment (RoHS).

Soldering

Soldering recommendations available upon request or from www.kionix.com.



± 10g Tri-Axis Accelerometer Specifications

PART NUMBER:

KXD94-2802

Rev. -
Dec 08

Application Schematic

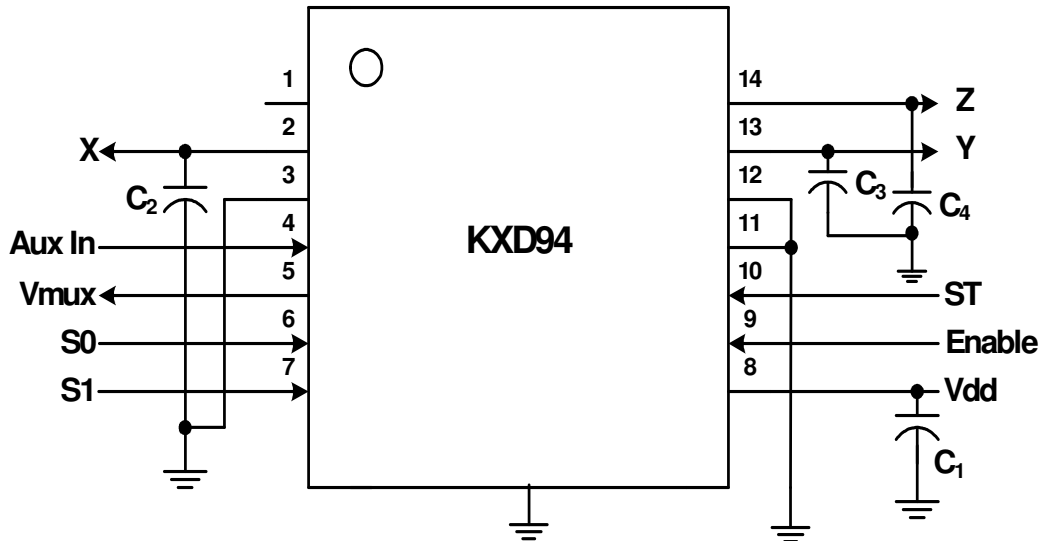

Table 4. KXD94 Pad Descriptions

Pad	Name	Description
1	NC	Not Connected Internally (can be connected to Vdd or Gnd)
2	X output	Analog output of the x-channel. Optionally, a capacitor (C ₂) placed between this pin and ground will form a low pass filter.
3	GND	Ground
4	GND	Ground
5	VMUX	VMUX output – buffered analog output for X channel
6	S0	MUX selector 0 (See Output Select Table). Connect to Vdd or Ground if not used.
7	S1	MUX selector 1 (See Output Select Table). Connect to Vdd or Ground if not used.
8	Vdd	The power supply input. Decouple this pin to ground with a 0.1uF ceramic capacitor (C ₁).
9	Enable	Enable: High - Normal operation; Low - Device is in standby, power down mode
10	ST	Self Test. The output of a properly functioning part will increase when Vdd is applied to the self-test pin. (See Table 2)
11	NC	Not Connected Internally (can be connected to Vdd or Gnd)
12	GND	Ground
13	Y output	Analog output of the y-channel. Optionally, a capacitor (C ₃) placed between this pin and ground will form a low pass filter.
14	Z output	Analog output of the z-channel. Optionally, a capacitor (C ₄) placed between this pin and ground will form a low pass filter.
	Center pad	Ground

	± 10g Tri-Axis Accelerometer Specifications	PART NUMBER: KXD94-2802 Rev. - Dec 08
---	--	--

Application Design Equations

1. The internal 1kHz low pass filter determines the bandwidth. The user can lower the bandwidth by placing filter capacitors connected from pin 2, 13, and 14 to ground. The response is single pole. Given a desired bandwidth, f_{BW} , the filter capacitors are determined by:

$$C_2 = C_3 = C_4 = \frac{4.97 \times 10^{-6}}{f_{BW}}$$

2. The response time (RT) is determined by the equation:

$$RT = 5 \times R_{int} \times C_{ext}$$

R_{int} is the 32KΩ internal resistor and C_{ext} is the external resistor C_2 , C_3 , or C_4 .

Using the Multiplexed Output of the KXD94

Multiplexer Data Select

The KXD94 features an integrated 4-channel multiplexer. This feature reduces system MCU requirements to only 1 ADC and 2 digital I/O's. The KXD94 uses two select inputs (S0, S1) to control the data flow from V_{mux} . When a microprocessor toggles the select inputs, the desired output is attained based on the select table. See Table 2 for Logic 0 and Logic 1 voltage levels.

Table 5. Output Select Table

S1	S0	V_{mux}
0	0	X Output
0	1	Z Output
1	0	Y Output
1	1	Aux. In

	± 10g Tri-Axis Accelerometer Specifications	PART NUMBER: KXD94-2802 Rev. - Dec 08
---	--	--

Data Sampling Rate

When operating in its multiplexed mode, the KXD94 has the ability to achieve very high data sampling rates. Internally, the sensor elements (X, Y, and Z) are sequentially sampled in a “round robin” fashion at a rate of 32KHz per axis. Note that this is a differential capacitance sampling of each sensor element, which stores an analog voltage on the filter cap for each axis. Combine this high sensor element sampling rate with the short 5µS settling time of the integrated multiplexer, and the user can achieve a performance very close to that of the 3 separate analog outputs. This is more than sufficient to eliminate any aliasing in the final application since the KXD94 will be operating with a typical bandwidth of ~50Hz and a maximum of 1000Hz.

Test Specifications



Special Characteristics:

These characteristics have been identified as being critical to the customer. Every part is tested to verify its conformance to specification prior to shipment.

Table 6. Test Specifications

Parameter	Specification	Test Conditions
Zero-g Offset @ RT	2.50 ± 0.05 V	25°C, V _{dd} = 5.0V
Sensitivity @ RT	200 ± 7 mV/g	25°C, V _{dd} = 5.0V
Current Consumption	Operating	25°C, V _{dd} = 5.0V



± 10g Tri-Axis Accelerometer Specifications

PART NUMBER:

KXD94-2802

**Rev. -
Dec 08**

Package Dimensions and Orientation: 5 x 5 x 1.2mm 14 pin DFN

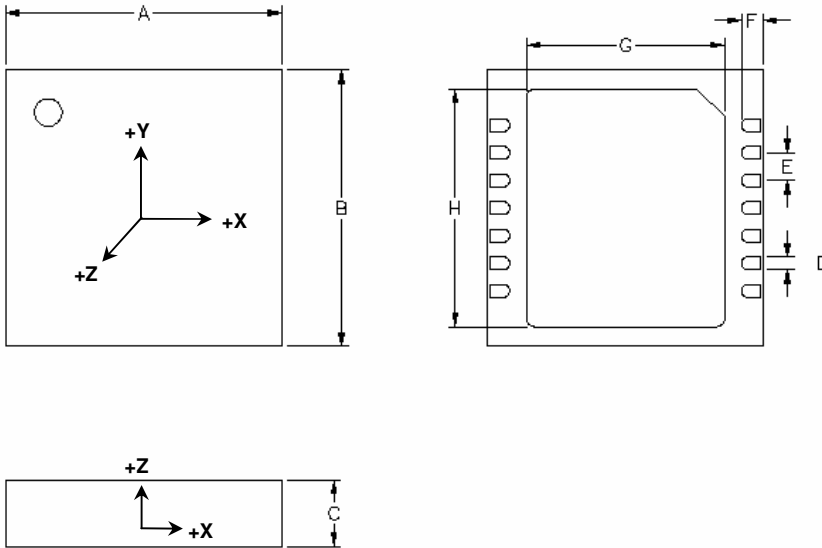





All dimensions and tolerances conform to ASME Y14.5M-1994

Dimension	mm			inch		
	Min	Nom	Max	Min	Nom	Max
A		5.00			0.197	
B		5.00			0.197	
C	1.10	1.20	1.30	0.043	0.047	0.051
D	0.18	0.23	0.28	0.007	0.009	0.011
E		0.50			0.020	
F	0.35	0.40	0.45	0.014	0.016	0.018
G	3.50	3.60	3.70	0.138	0.142	0.146
H	4.20	4.30	4.40	0.165	0.169	0.173

	± 10g Tri-Axis Accelerometer Specifications	PART NUMBER: KXD94-2802 Rev. - Dec 08
---	--	---

When device is accelerated in +X, +Y, or +Z direction, the output will increase.

Static X/Y/Z Output Response versus Orientation to Earth's surface (1g):

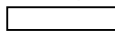
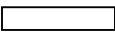
Position	1	2	3	4	5	6
Diagram					Top  Bottom	Bottom  Top
X	2.50 V	2.70 V	2.50 V	2.30 V	2.50 V	2.50 V
Y	2.70 V	2.50 V	2.30 V	2.50 V	2.50 V	2.50 V
Z	2.50 V	2.50 V	2.50 V	2.50 V	2.70 V	2.30 V
X-Polarity	0	+	0	-	0	0
Y-Polarity	+	0	-	0	0	0
Z-Polarity	0	0	0	0	+	-

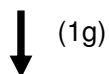

Earth's Surface