





## Dual (X,Y) Axis Accelerometer Specifications

PART NUMBER:  
KXM52-1048

### Product Description

The KXM52-1048 is a dual axis, analog output silicon micromachined accelerometer with a full-scale output range of  $\pm 2.0g$  ( $19.6 \text{ m/s}^2$ ). Plasma micromachining is used to fabricate the sense element using Kionix's proprietary deep reactive ion etch processes. Kionix linear accelerometers function on the principle of differential capacitance; acceleration causes displacement of a silicon structure resulting in a capacitance change. Common mode cancellation is used to decrease errors from process variation, temperature, and environmental stress. The sense element is hermetically sealed at the wafer level by bonding a silicon lid wafer to the device using glass frit. A separate ASIC device packaged with the sense element provides signal conditioning and self-test. The accelerometer is delivered in a 5 x 5 x 1.8 mm Dual Flat No-lead (DFN) package.

### Functional Diagram

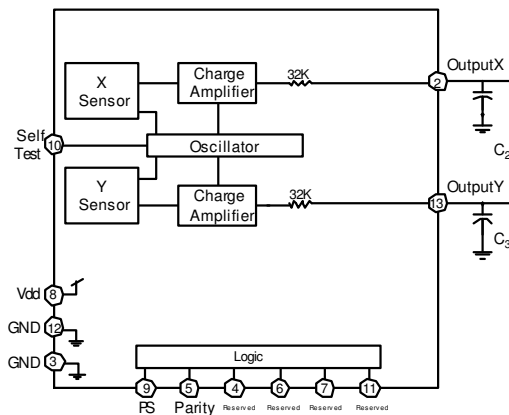

	<b>Dual (X,Y) Axis Accelerometer Specifications</b>	<b>PART NUMBER:</b>  <b>KXM52-1048</b>
---	---	--

## Product Specifications

**Table 1. Mechanical**

(specifications are for operation at  $V_{dd} = 3.3V$  and  $T = 25^{\circ}C$  unless stated otherwise)

Parameters	Units	Min	Target	Max
Operating Temperature Range	$^{\circ}C$	-40	-	85
Zero-g Offset	V	1.617	1.650	1.683
Zero-g Offset Variation from RT over Temp.	mg	-150	-	150
Sensitivity	mV/g	653	660	667
Sensitivity Variation from RT over Temp.	%	-2	0	+2
Offset Ratiometric Error ( $V_{dd} = 3.3V \pm 5\%$ )	%	-	0.4	1.5
Sensitivity Ratiometric Error ( $V_{dd} = 3.3V \pm 5\%$ )	%	-	0.4	1.5
Non-Linearity	% of FS	-	0.1	0.5
Cross Axis Sensitivity	%	-	2.0	3.0
Self Test Output change on Activation	g	1.0	1.1	1.2
Bandwidth (-3dB) <sup>1</sup>	Hz	-	-	3100
Noise Density (on filter pins)	$\mu g / \sqrt{Hz}$	-	35	100

Notes:

1. User definable with external capacitors. Maximum defined by the frequency response of the sensors.

**Table 2. Electrical**

(specifications are for operation at  $V_{dd} = 3.3V$  and  $T = 25^{\circ}C$  unless stated otherwise)

Parameters	Units	Min	Target	Max	
Supply Voltage ( $V_{dd}$ )	Operating	V	2.5	3.3	5.5
Current Consumption	Operating <sup>1</sup>	mA	1.3	1.7	2.3
	Standby	$\mu A$	-	-	10
Analog Output Resistance( $R_{out}$ )	$k\Omega$	24	32	40	
Power Up Time <sup>1</sup>	ms		$5 \cdot R_{out} \cdot C$		

Notes:

1. Power up time is determined by 5 times the RC time constant of the user defined low pass filter.

	<b>Dual (X,Y) Axis Accelerometer Specifications</b>	<b>PART NUMBER:</b> <b>KXM52-1048</b>
---	---	--

**Table 3. Environmental**

Parameters		Units	Min	Target	Max
Supply Voltage ( $V_{dd}$ )	Absolute Limits	V	-0.3	-	7.0
Operating Temperature Range		°C	-40	-	85
Storage Temperature Range		°C	-55	-	150
Mech. Shock (powered and unpowered)		g	-	-	4600 for 0.5ms
ESD	HBM	V	-	-	3000

CAUTION:  
ELECTROSTATIC  
SENSITIVE COMPONENT



Caution: ESD Sensitive and Mechanical Shock Sensitive Component, improper handling can cause permanent damage to the device.

The 14-pin DFN package conforms to European Union Directive 2002/95/EC on the restriction of the use of certain hazardous substances in electrical and electronic equipment (RoHS).



## Dual (X,Y) Axis Accelerometer Specifications

PART NUMBER:  
KXM52-1048

### Application Schematic and Pin Function Table

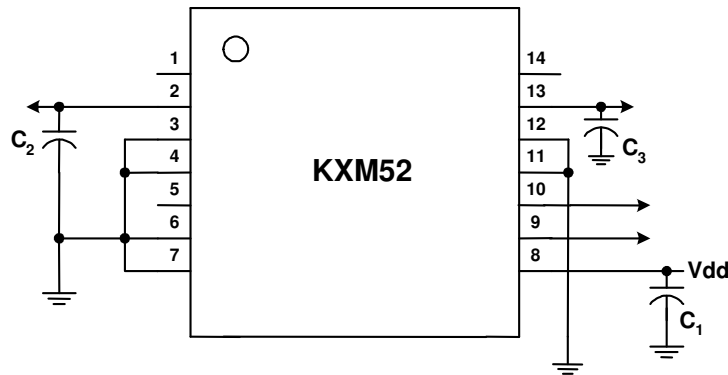



Table 4. KXM52 Pin Descriptions

Pin	Name	Description
1	NC	Not Connected Internally.
2	X Output	Analog output of the x-channel. Optionally, a capacitor ( $C_2$ ) placed between this pin and ground will form a low pass filter.
3	GND	Ground
4	Reserved	Factory reserved. Connect this pin to ground.
5	Parity	Checks EEPROM for parity error.
6	Reserved	Factory reserved. Connect this pin to ground.
7	Reserved	Factory reserved. Connect this pin to ground.
8	Vdd	The power supply input. Decouple this pin to ground with a 0.1 $\mu$ F ceramic capacitor ( $C_1$ ).
9	PS	When the PS pin is connected to GND or left floating, the KXM52 is shutdown and drawing very little power. When the PS pin is tied to Vdd, the unit is fully functional.
10	ST	Self Test. Output X, Output Y, and Output Z of a properly functioning part will increase when Vdd is applied to the self test pin.
11	Reserved	Factory reserved. Connect this pin to ground.
12	GND	Ground
13	Y Output	Analog output of y-channel. Optionally, a capacitor ( $C_3$ ) placed between this pin and ground will form a low pass filter.
14	DNC	Do Not Connect

### Application Design Equations

The bandwidth is determined by the filter capacitors connected from pins 2 and 13 to ground. The response is single pole. Given a desired bandwidth,  $f_{BW}$ , the filter capacitors are determined by:

$$C_2 = C_3 = \frac{4.97 \times 10^{-6}}{f_{BW}}$$

	<b>Dual (X,Y) Axis Accelerometer Specifications</b>	<b>PART NUMBER:</b> <b>KXM52-1048</b>
---	---	--

## Test Specifications

### **Special Characteristics:**

These characteristics have been identified as being critical to the customer. Every part is tested to verify its conformance to specification prior to shipment.

Parameters	Specification	Test Conditions
Zero-g Offset @ RT	1.650 ± 0.033 V	25°C, V <sub>dd</sub> = 3.3V
Sensitivity @ RT	660 ± 7 mV/g	25°C, V <sub>dd</sub> = 3.3V
Cross Axis Sensitivity	< 3%	25°C, V <sub>dd</sub> = 3.3V
Current Consumption	Operating	25°C, V <sub>dd</sub> = 3.3V



# Dual (X,Y) Axis Accelerometer Specifications

**PART NUMBER:**  
**KXM52-1048**

## Package Dimensions

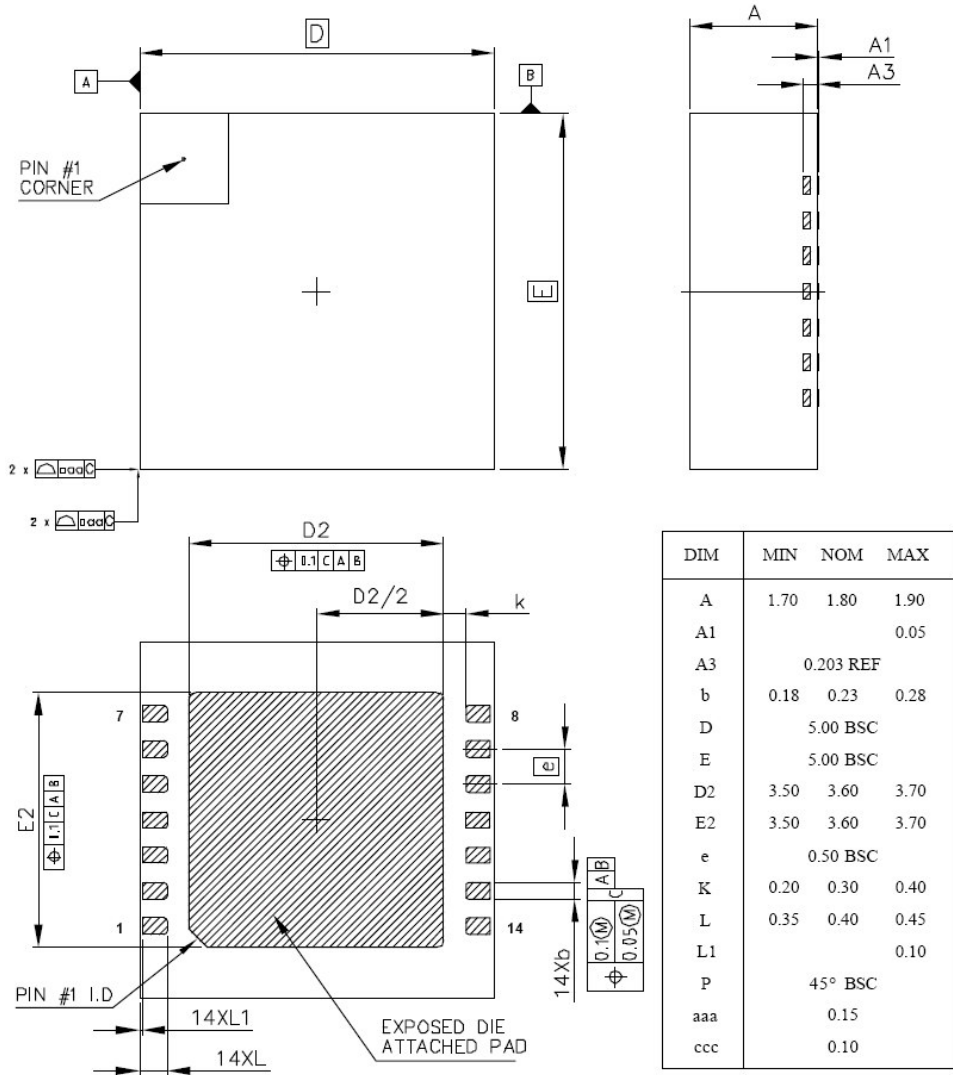



## Dual (X,Y) Axis Accelerometer Specifications

PART NUMBER:  
KXM52-1048

### NOTES

- 1.0 DIMENSIONING & TOLERANCEING CONFIRM TO ASME Y14.5M-1994.
- 2.0 ALL DIMENSIONS ARE IN MILLIMETERS. ANGLES ARE IN DEGREES.
- 3.0 DIMENSION  $b$  APPLIES TO METALLIZED TERMINAL AND IS MEASURED BETWEEN 0.25mm AND 0.30mm FROM TERMINAL TIP. DIMENSION  $L1$  REPRESENTS TERMINAL FULL BACK FROM PACKAGE EDGE UP TO 0.1mm IS ACCEPTABLE.
- 4.0 COPLANARITY APPLIES TO THE EXPOSED HEAT SLUG AS WELL AS THE TERMINAL.
- 5.0 RADIUS ON TERMINAL IS OPTIONAL.

### Package Orientation

