



± 2 g Tri-Axis Analog Accelerometer Specifications

PART NUMBER:
KXPA4-1050

Product Description

The KXPA4-1050 is a tri-axis, analog output, silicon micromachined accelerometer with a full-scale output range of $\pm 2.0g$ (19.6 m/s^2). The sense element is fabricated using Kionix's proprietary plasma micromachining process technology. Acceleration sensing is based on the principle of a differential capacitance arising from acceleration-induced motion of the sense element, which further utilizes common mode cancellation to decrease errors from process variation, temperature, and environmental stress. The sense element is hermetically sealed at the wafer level by bonding a second silicon lid wafer to the device using a glass frit. A separate ASIC device packaged with the sense element provides signal conditioning and self-test. The accelerometer is delivered in an $5 \times 5 \times 1.2\text{mm}$ Dual Flat No-lead (DFN) plastic package operating from a 2.7 - 5V DC supply. The KXPA4 also features an integrated 3-channel multiplexer. This feature reduces system MCU requirements to only 1 ADC and 2 digital I/O's.

Functional Diagram

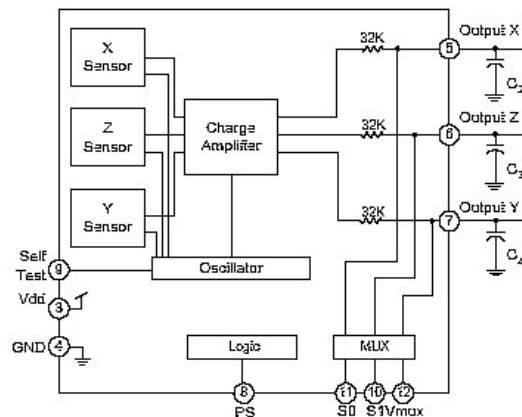

	± 2 g Tri-Axis Analog Accelerometer Specifications	PART NUMBER: KXPA4-1050
---	---	------------------------------------

Product Specifications

Table 1. Mechanical

(specifications are for operation at $V_{dd} = 2.8V$ and $T = 25^{\circ}C$ unless stated otherwise)

Parameters	Units	Min	Target	Max
Operating Temperature Range	$^{\circ}C$	-40	-	85
Zero-g Offset	V	1.26	1.40	1.54
Zero-g Offset Variation from RT over Temp.	mg	-150 (xy) -300 (z)	-	150 (xy) 300 (z)
Sensitivity	mV/g	543	560	577
Sensitivity Variation from RT over Temp.	%	-2	0	+2
Offset Ratiometric Error ($V_{dd} = 2.8V \pm 5\%$)	%	-	0.4	1.5
Sensitivity Ratiometric Error ($V_{dd} = 2.8V \pm 5\%$)	%	-	0.4	1.5
Non-Linearity	% of FS	-	0.1	0.5
Cross Axis Sensitivity	%	-	2.0	3.0
Self Test Output change on Activation	g	0.8 (xy) 0.6 (z)	1.1 (xy) 0.8 (z)	1.3 (xy) 1.0 (z)
Bandwidth (-3dB) ¹	Hz	-	3300 (xy) 1700 (z)	-
Noise Density (on filter pins)	$\mu g / \sqrt{Hz}$	-	175	250

Notes:

1. User definable with external capacitors. Maximum defined by the frequency response of the sensors.

Table 2. Electrical

(specifications are for operation at $V_{dd} = 2.8V$ and $T = 25^{\circ}C$ unless stated otherwise)

Parameters		Units	Min	Target	Max
Supply Voltage (V_{dd})	Operating	V	2.7	2.8	5.25
Current Consumption	Operating ¹	mA	0.6	1.1	1.5
	Standby	μA	-	-	10
Analog Output Resistance(R_{out})		k Ω	24	32	40
Power Up Time ¹		ms		$5 * R_{out} * C$	

Notes:

1. Power up time is determined by 5 times the RC time constant of the user defined low pass filter.

	± 2 g Tri-Axis Analog Accelerometer Specifications	PART NUMBER: KXPA4-1050
---	---	------------------------------------

Table 3. Environmental

Parameters		Units	Min	Target	Max
Supply Voltage (V_{dd})	Absolute Limits	V	-0.3	-	7.0
Operating Temperature Range		°C	-40	-	85
Storage Temperature Range		°C	-55	-	150
Mech. Shock (powered and unpowered)		g	-	-	4600 for 0.5ms
ESD	HBM	V	-	-	3000

CAUTION:
ELECTROSTATIC
SENSITIVE COMPONENT



Caution: ESD Sensitive and Mechanical Shock Sensitive Component, improper handling can cause permanent damage to the device.

The 14-pin DFN package conforms to European Union Directive 2002/95/EC on the restriction of the use of certain hazardous substances in electrical and electronic equipment (RoHS).

Soldering

Soldering recommendations available upon request or from www.kionix.com.



± 2 g Tri-Axis Analog Accelerometer Specifications

PART NUMBER:
KXPA4-1050

Application Schematic

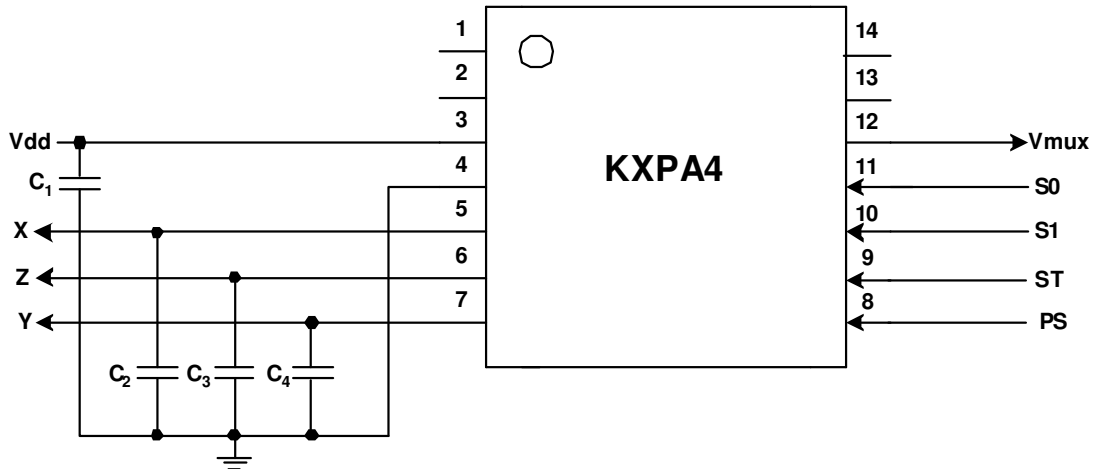

Table 4. KXPA4 Pin Descriptions

Pin	Name	Description
1	NC	Not Connected Internally
2	NC	Not Connected Internally
3	Vdd	The power supply input. Decouple this pin to ground with a 0.1µF ceramic capacitor (C ₁).
4	GND	Ground
5	X Output	Analog output of the x-channel. Optionally, a capacitor (C ₂) placed between this pin and ground will form a low pass filter.
6	Z Output	Analog output of z-channel. Optionally, a capacitor (C ₄) placed between this pin and ground will form a low pass filter.
7	Y Output	Analog output of y-channel. Optionally, a capacitor (C ₃) placed between this pin and ground will form a low pass filter.
8	PS	Power shutdown pin.
9	ST	Self Test. The output of a properly functioning part will increase when Vdd is applied to the self-test pin.
10	S1	MUX select
11	S0	MUX select
12	Vmux	Multiplexed analog output
13	NC	Not Connected Internally
14	NC	Not Connected Internally

Application Design Equations

The bandwidth is determined by the filter capacitors connected from pins 5, 6 and 7 to ground. The response is single pole. Given a desired bandwidth, f_{BW} , the filter capacitors are determined by:

$$C_2 = C_3 = C_4 = \frac{4.97 \times 10^{-6}}{f_{BW}}$$

Note:

When the PS pin is connected to GND or left floating, the KXPA4 is shutdown and drawing very little power. When the PS pin is tied to Vdd, the unit is fully functional.

	± 2 g Tri-Axis Analog Accelerometer Specifications	PART NUMBER: KXPA4-1050
---	---	------------------------------------

USING THE MULTIPLEXED OUTPUT OF THE KXPA4

Multiplexer Data Select

The KXPA4 features an integrated 3-channel multiplexer. This feature reduces system MCU requirements to only 1 ADC and 2 digital I/O's. The KXPA4 uses two select (S0, S1) inputs to control the data flow from Vmux. When a microprocessor toggles the select inputs, the desired output is attained based on the select table. Note that logic 0 is GND and logic 1 is Vdd.

S1	S0	Vmux
0	0	X Output
0	1	Z Output
1	0	Y Output
1	1	Y Output

Output Select Table

Data Sampling Rate

When operating in its multiplexed mode, the KXPA4 has the ability to achieve very high data sampling rates. Internally, the sensor elements (X, Y, and Z) are sequentially sampled in a "round robin" fashion at a rate of 32KHz per axis. Note that this is a differential capacitance sampling of each sensor element, which stores an analog voltage on the filter cap for each axis. Combine this high sensor element sampling rate with the short 5µS settling time of the integrated multiplexer, and the user can achieve a performance very close to that of the 3 separate analog outputs. This is more than sufficient to eliminate any aliasing in the final application since the KXPA4 will be operating with a typical bandwidth of ~50Hz and a maximum of 2500Hz.

	± 2 g Tri-Axis Analog Accelerometer Specifications	PART NUMBER: KXPA4-1050
---	---	------------------------------------

[Test Specifications](#)



Special Characteristics:

These characteristics have been identified as being critical to the customer. Every part is tested to verify its conformance to specification prior to shipment.

Table 5. Test Specifications

Parameter	Specification	Test Conditions
Zero-g Offset @ RT	1.400 ± 0.140 V	25°C, V _{dd} = 2.8V
Sensitivity @ RT	560 ± 17 mV/g	25°C, V _{dd} = 2.8V
Cross Axis Sensitivity	< 3%	25°C, V _{dd} = 2.8V
Current Consumption	Operating 0.6 ≤ I _{dd} ≤ 1.5 mA	25°C, V _{dd} = 2.8V



± 2 g Tri-Axis Analog Accelerometer Specifications

PART NUMBER:
KXPA4-1050

Package Dimensions and Orientation

5 x 5 x 1.2 mm DFN

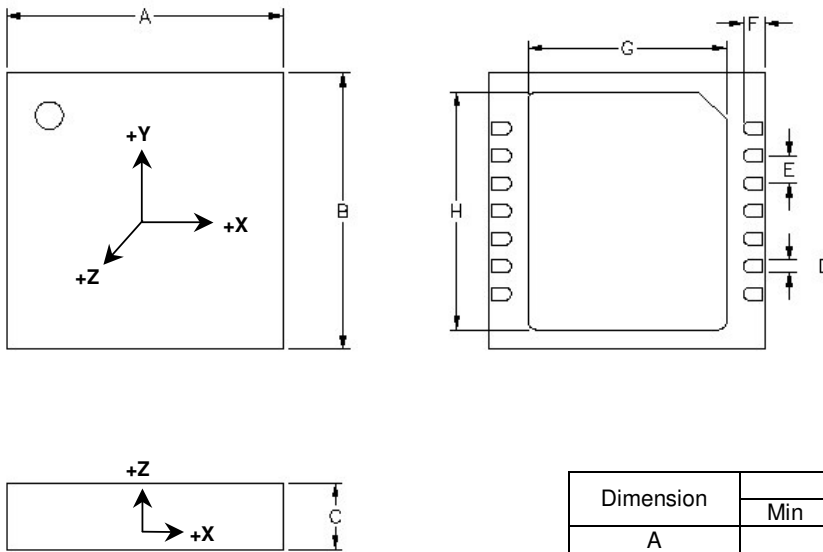

Dimension	mm			inch		
	Min	Nom	Max	Min	Nom	Max
A		5.00			0.197	
B		5.00			0.197	
C	1.10	1.20	1.30	0.043	0.047	0.051
D	0.18	0.23	0.28	0.007	0.009	0.011
E		0.50			0.020	
F	0.35	0.40	0.45	0.014	0.016	0.018
G	3.50	3.60	3.70	0.138	0.142	0.146
H	4.20	4.30	4.40	0.165	0.169	0.173

All dimensions and tolerances conform to ASME Y14.5M-1994

When device is accelerated in +X, +Y or +Z direction, the corresponding output will increase.