



## ± 2g Tri-axis Analog Accelerometer Specifications

PART NUMBER:

KXSC7-2050  
Rev. 4  
Apr-2009

### Product Description

The KXSC7-2050 is a Tri-axis, silicon micromachined accelerometer with a full-scale output range of  $\pm 2g$  (19.6 m/s/s). The sense element is fabricated using Kionix's proprietary plasma micromachining process technology. Acceleration sensing is based on the principle of a differential capacitance arising from acceleration-induced motion of the sense element, which further utilizes common mode cancellation to decrease errors from process variation, temperature, and environmental stress. The sense element is hermetically sealed at the wafer level by bonding a second silicon lid wafer to the device using a glass frit. A separate ASIC device packaged with the sense element provides signal conditioning and self-test. The accelerometer is delivered in a 3 x 3 x 0.9mm Land Grid Array (LGA) plastic package operating from a 1.8 – 3.6V DC supply. The KXSC7 features a factory programmable low pass filter and an inertial wakeup interrupt.

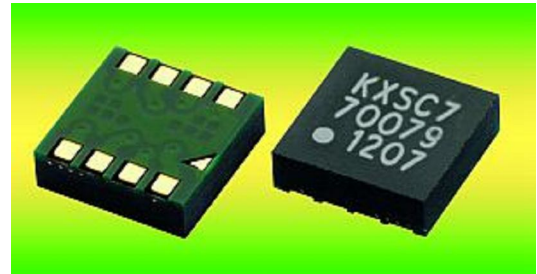

### Functional Diagram

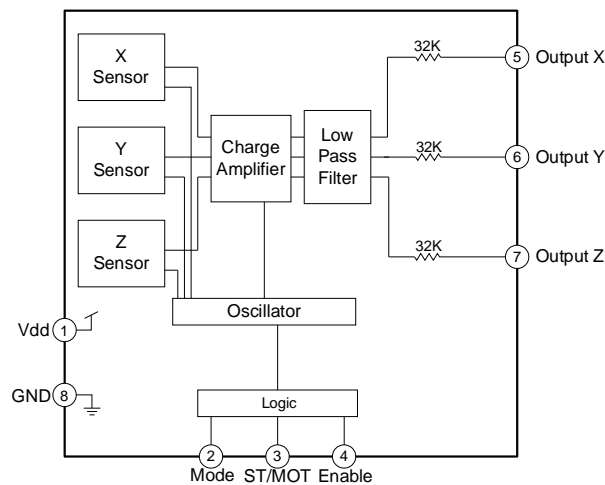

	<b>± 2g Tri-axis Analog Accelerometer Specifications</b>	<b>PART NUMBER:</b>  <b>KXSC7-2050</b> <b>Rev. 4</b> <b>Apr-2009</b>
---	--	--

## Product Specifications

**Table 1. Mechanical**

(specifications are for operation at 3.3V and T = 25C unless stated otherwise)

Parameters	Units	Min	Typical	Max
Operating Temperature Range	°C	-40	-	85
Zero-g Offset	V	1.485	1.65	1.815
Zero-g Offset Variation from RT over Temp.	mg/°C		0.5 (xy) 3 (z)	
Sensitivity	mV/g	640	660	680
Sensitivity Variation from RT over Temp.	%/°C		0.01 (xy) 0.04 (z)	
Offset Ratiometric Error ( $V_{dd} = 3.3V \pm 5\%$ )	%		0.3	
Sensitivity Ratiometric Error ( $V_{dd} = 3.3V \pm 5\%$ )	%		1.1 (xy) 0.6 (z)	
Self Test Output change on Activation	g		1.4 (xy) 0.6 (z)	
Mechanical Resonance (-3dB) <sup>1</sup>	Hz		4000 (xy) 2000 (z)	
Non-Linearity	% of FS		2	
Cross Axis Sensitivity	%		2	
Noise Density (on filter pins)	µg / √Hz		100	
Motion Interrupt Threshold	g		1.5	

Notes:

1. Resonance as defined by the dampened mechanical sensor.

**Table 2. Electrical**

(specifications are for operation at 3.3V and T = 25C unless stated otherwise)

Parameters	Units	Min	Typical	Max	
Supply Voltage ( $V_{dd}$ )	Operating	V	1.8	3.3	3.6
Current Consumption	Operating (full power)	µA	160	230	300
	Operating (low power)	µA	-	50	
	Standby	µA	-	5	
Analog Output Resistance ( $R_{out}$ )	kΩ	24	32	40	
Power Up Time <sup>1</sup>	ms	-	5* $R_{out}$ *C	-	
Bandwidth (-3dB) <sup>2</sup>	Hz	40	50	60	

Notes:

1. Power up time is determined by 5 times the RC time constant of the factory programmed or user defined low pass filter.

	<b>± 2g Tri-axis Analog Accelerometer Specifications</b>	<b>PART NUMBER:</b>  <b>KXSC7-2050</b> <b>Rev. 4</b> <b>Apr-2009</b>
---	--	--

2. Factory programmable to have a switched capacitor low pass filter at 2kHz, 1kHz, 500Hz, 100Hz, 50Hz, or no low pass filter. Optionally, the user can define with external capacitors. Maximum defined by the frequency response of the sensors.

**Table 3. Environmental**

Parameters		Units	Min	Typical	Max
Supply Voltage ( $V_{dd}$ )	Absolute Limits	V	-0.3	-	6.0
Operating Temperature Range		°C	-40	-	85
Storage Temperature Range		°C	-55	-	150
Mech. Shock (powered and unpowered)		g	-	-	5000 for 0.5ms 10000 for 0.2ms
ESD	HBM	V	-	-	2000



Caution: ESD Sensitive and Mechanical Shock Sensitive Component, improper handling can cause permanent damage to the device.



This product conforms to Directive 2002/95/EC of the European Parliament and of the Council of the European Union (RoHS). Specifically, this product does not contain lead, mercury, cadmium, hexavalent chromium, polybrominated biphenyls (PBB), or polybrominated diphenyl ethers (PBDE) above the maximum concentration values (MCV) by weight in any of its homogenous materials. Homogenous materials are "of uniform composition throughout."



This product is halogen-free per IEC 61249-2-21. Specifically, the materials used in this product contain a maximum total halogen content of 1500 ppm with less than 900-ppm bromine and less than 900-ppm chlorine.

### Soldering

Soldering recommendations are available upon request or from [www.kionix.com](http://www.kionix.com).



# ± 2g Tri-axis Analog Accelerometer Specifications

**PART NUMBER:**  
KXSC7-2050  
Rev. 4  
Apr-2009

## Application Schematic

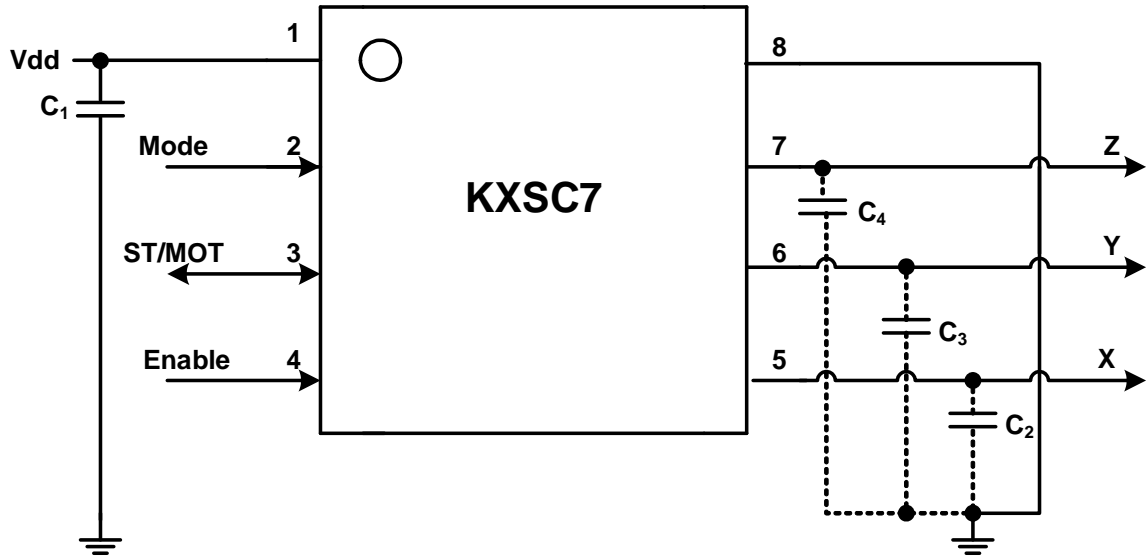

**Table 4. KXSC7 Pin Descriptions**

Pin	Name	Description
1	Vdd	The power supply input. Decouple this pin to ground with a 0.1uF ceramic capacitor (C <sub>1</sub> ).
2	Mode	Mode selection (1=normal operating mode, 0 = low power, motion interrupt mode)
3	ST / MOT	Self Test / Motion Interrupt
4	Enable	Enable (1 = Enabled, 0 = Disabled)
5	X Output	Analog output of the x-channel. Optionally, a capacitor (C <sub>2</sub> ) placed between this pin and ground will form a low pass filter.
6	Y Output	Analog output of the y-channel. Optionally, a capacitor (C <sub>3</sub> ) placed between this pin and ground will form a low pass filter.
7	Z Output	Analog output of the z-channel. Optionally, a capacitor (C <sub>4</sub> ) placed between this pin and ground will form a low pass filter.
8	GND	Ground

## Application Design Equations

The bandwidth is determined by a factory programmable switched capacitor filter. The filter can be set at the factory to be 2kHz, 1kHz, 500Hz, 100Hz, 50Hz, or no low pass filter. Alternatively, bandwidth can be reduced by addition of a capacitor on the output pins 5, 6, and 7 according to the equation:

$$C_2 = C_3 = C_4 = \frac{4.97 \times 10^{-6}}{f_{BW}}$$

**Note:**

When the Enable pin is connected to GND or left floating, the KXSC7 is shutdown and drawing very little power. When the Enable pin is tied to Vdd, the unit is fully functional.



# ± 2g Tri-axis Analog Accelerometer Specifications

PART NUMBER:  
KXSC7-2050  
Rev. 4  
Apr-2009

## USING THE LOW POWER INERTIAL WAKEUP OF THE KXSC7

The KXSC7 features a low power mode with an integrated motion interrupt. This feature allows for a reduction in overall system power consumption. When the Mode pin (pin 2) of the KXSC7 is tied low, the current consumption of the device drops to 50µA. The accelerometer is now sampling at a low frequency of 15Hz with a 6% duty cycle, looking for an acceleration event on any axis that exceeds the motion interrupt threshold. If the acceleration exceeds the threshold, the Motion interrupt pin (pin 3) transitions to the high output state and the accelerometer returns to its normal mode of operation. The accelerometer will remain in this state until the Mode pin is toggled high and low or the Enable pin is toggled low and high to enter low power mode again. Please see the Typical Motion Wake Up illustration and Mode Selection Table below for the control and logic needed to select the different modes of operation:

## Typical Motion Wake Up Interrupt Example

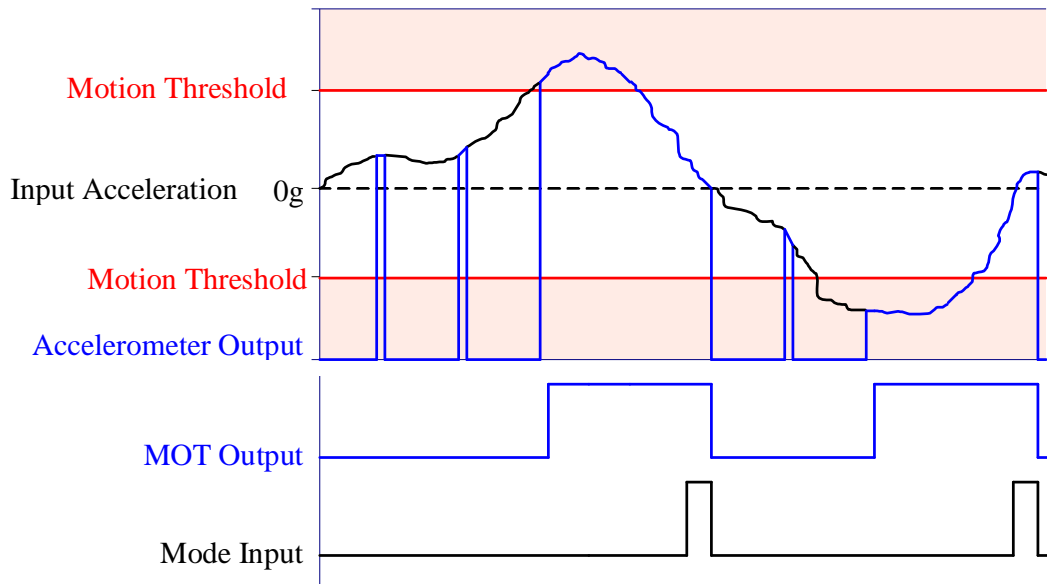

	<b>± 2g Tri-axis Analog Accelerometer Specifications</b>	<b>PART NUMBER:</b>  <b>KXSC7-2050</b> <b>Rev. 4</b> <b>Apr-2009</b>
---	--	--

**Mode Selection Table**

Pin	Normal mode	Normal mode with Self Test Activated	Low power mode with Motion Interrupt	Standby mode
Enable (4)	Position: <b>High</b> Function: Enable Direction: Input	Position: <b>High</b> Function: Enable Direction: Input	Position: <b>High</b> Function: Enable Direction: Input	Position: <b>Low</b> Function: Enable Direction: Input
Mode (2)	Position: <b>High</b> Function: Mode Direction: Input	Position: <b>High</b> Function: Mode Direction: Input	Position: <b>Low</b> Function: Mode Direction: Input	Disabled
ST / MOT (3)	Position: <b>Low</b> Function: Self Test Direction: Input	Position: <b>High</b> Function: Self Test Direction: Input	Position: Function: Motion Interrupt Direction: Output	Disabled

- Notes: 1) The Motion Interrupt will only be functional while in the low power mode.  
2) When the part is in low power mode and a motion interrupt has occurred the part will enter normal operating mode until the Mode pin is toggled high and low or the Enable pin is toggled low and high to enter low power mode again.

To provide an inertial wakeup to the end system, a microprocessor should place the Mode pin in the low state. If the MOT pin remains low for some pre-determined period of time, the system is not moving and the microprocessor can shutdown functions that consume power. When the MOT pin transitions high, the microprocessor can wake up those functions and provide full operation to the user. Once accelerations have remained constant and below a pre-determined threshold, the microprocessor can again place the KXSC7 into the low power mode and shutdown functions that consume power.

	<b>± 2g Tri-axis Analog Accelerometer Specifications</b>	<b>PART NUMBER:</b>  <b>KXSC7-2050</b> <b>Rev. 4</b> <b>Apr-2009</b>
---	--	--

## Test Specifications



### *Special Characteristics:*

These characteristics have been identified as being critical to the customer. Every part is tested to verify its conformance to specification prior to shipment.

**Table 5. Test Specifications**

Parameter	Specification	Test Conditions
Zero-g Offset @ RT	1.65 +/- 0.165 V	25C, Vdd = 3.3 V
Sensitivity @ RT	660 +/- 20 mV/g	25C, Vdd = 3.3 V
Current Consumption -- Operating	160 <= Idd <= 300 uA	25C, Vdd = 3.3 V



# ± 2g Tri-axis Analog Accelerometer Specifications

PART NUMBER:  
KXSC7-2050  
Rev. 4  
Apr-2009

## Package Dimensions and Orientation

3 x 3 x 0.9 mm LGA

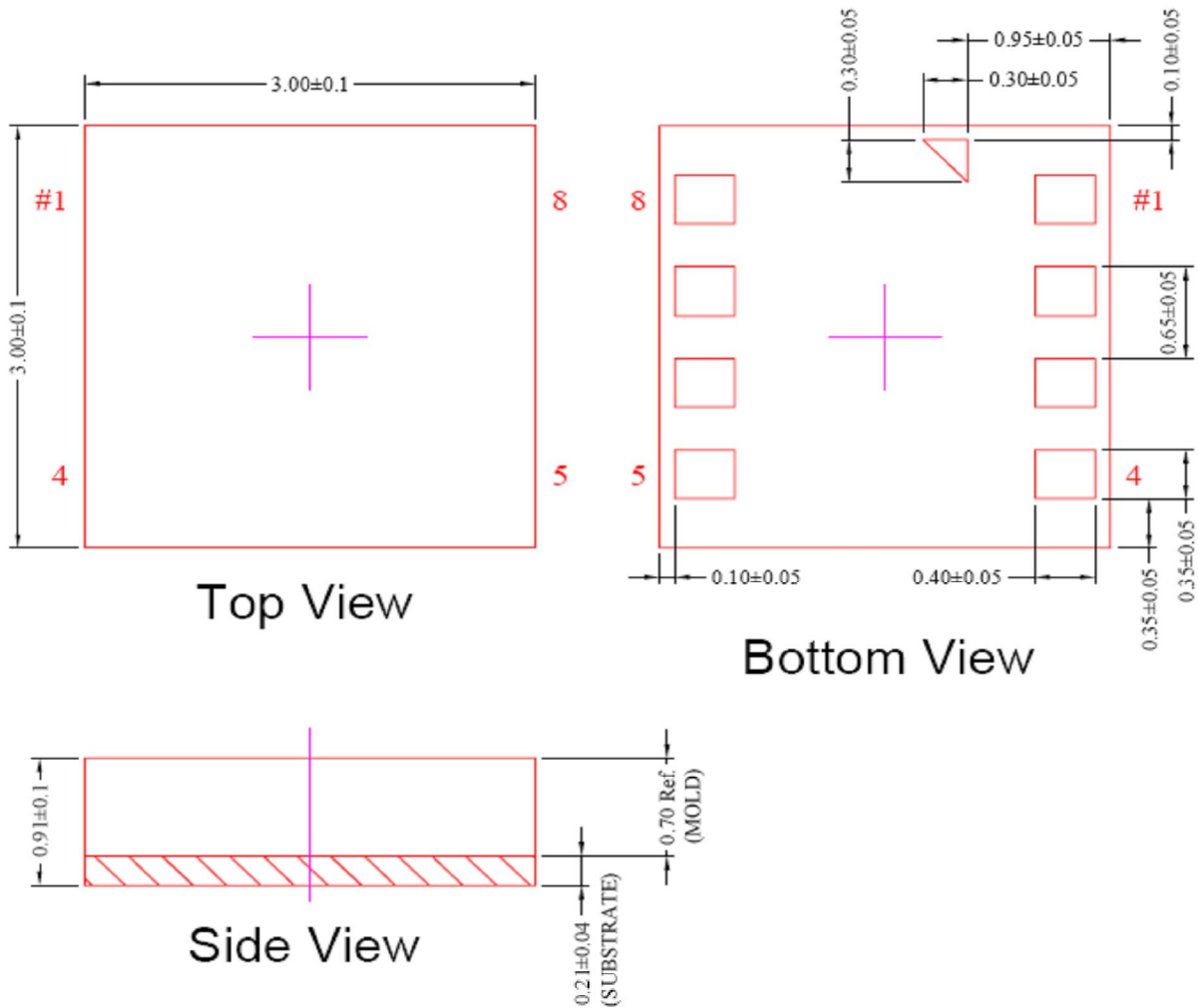

All dimensions and tolerances conform to ASME Y14.5M-1994



## ± 2g Tri-axis Analog Accelerometer Specifications

**PART NUMBER:**  
KXSC7-2050  
Rev. 4  
Apr-2009

### Static X/Y/Z Output Response versus Orientation to Earth's surface (1-g):

Position	1	2	3	4	5	6
Diagram					Top  Bottom	Bottom  Top
X	1.65 V	2.31 V	1.65 V	0.99 V	1.65 V	1.65 V
Y	2.31 V	1.65 V	0.99 V	1.65 V	1.65 V	1.65 V
Z	1.65 V	1.65 V	1.65 V	1.65 V	2.31 V	0.99 V
X-Polarity	0	+	0	-	0	0
Y-Polarity	+	0	-	0	0	0
Z-Polarity	0	0	0	0	+	-

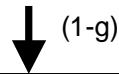

Earth's Surface

	<b>± 2g Tri-axis Analog Accelerometer Specifications</b>	<b>PART NUMBER:</b>  <b>KXSC7-2050</b> <b>Rev. 4</b> <b>Apr-2009</b>
---	--	--

### Revision History

REVISION	DESCRIPTION	DATE
1	Initial release	12-Oct-2007
2	Added Enable pin note	08-Jan-2008
3	Corrected filter pins, added HF designation	18-Nov-2008
4	Changed to new format & revisioning. Removed Enable pin note.	17-Apr-2009

"Kionix" is a registered trademark of Kionix, Inc. Products described herein are protected by patents issued or pending. No license is granted by implication or otherwise under any patent or other rights of Kionix. The information contained herein is believed to be accurate and reliable but is not guaranteed. Kionix does not assume responsibility for its use or distribution. Kionix also reserves the right to change product specifications or discontinue this product at any time without prior notice. This publication supersedes and replaces all information previously supplied.